

Instructions for MX5300 NFC KIOSK IV module Install UP-KIT

Mar.12.2024

Revision History

Rev.	Date	WRT	CHK	APL	Contents
00	Mar.12.2024	SHIN.CS	LEE.JO	LEE.DS	First Edition

Purpose, Part List







■ Purpose

These are the instructions for how to install NFC KIOSK IV module for MX5300

■ Tools

Screwdriver (+)	
-----------------	---

■ Parts

No	Part No.	Part Name	EA	Picture
1	5412000140	UNIT:VIVOPAY KIOSK IV(IDVK-411):IDTECH	1	
2	4210004801	SUPPORT:RF:EGI 1.2t:MX5300	1	
3	3368000005	ETC:RETAINER:COIL_105L:PVC_COATING:DABE2	1	
4	5721002549	LABEL:RF:MX5300A	1	
5	4610000007	SCREW:PH:TAP-2:WH:M3X6:W/ZN	4	
6	3400000084	USB_CABLE:AM TO MICB:STR:2.5M (MX5300A/S)	1	
7	33659001	TIE:CABLE:BLACK:100	2	

Work Process and Time

No	Step	Work Hours	Notes
1	Prepare to Assemble	5 mins	
2	Assemble NFC Module	10 mins	
Total		15 mins	

[Step 1] Prepare to Assemble

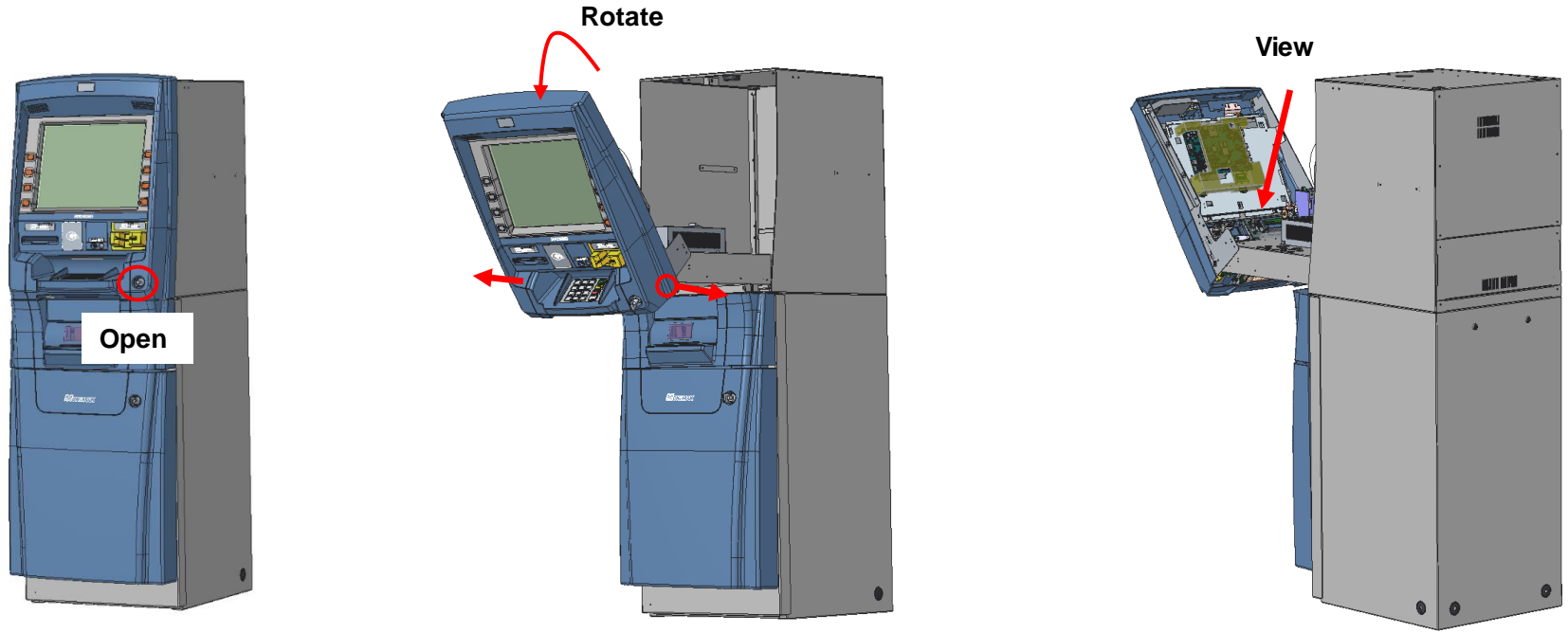

- Pull the front forward
- Loosen the two screws on both sides and rotate the front

[Step 2-1] Assembly NFC Module

No.	Part No.	Qty	Item
1	5412000140	1	UNIT:VIVOPAY KIOSK IV(IDVK-411):IDTECH
2	4210004801	1	SUPPORT:RF:EGI 1.2t:MX5300
3	3368000005	1	ETC:RETAINER:COIL_105L

① 5412000140 ② 4210004801 ③ 3368000005

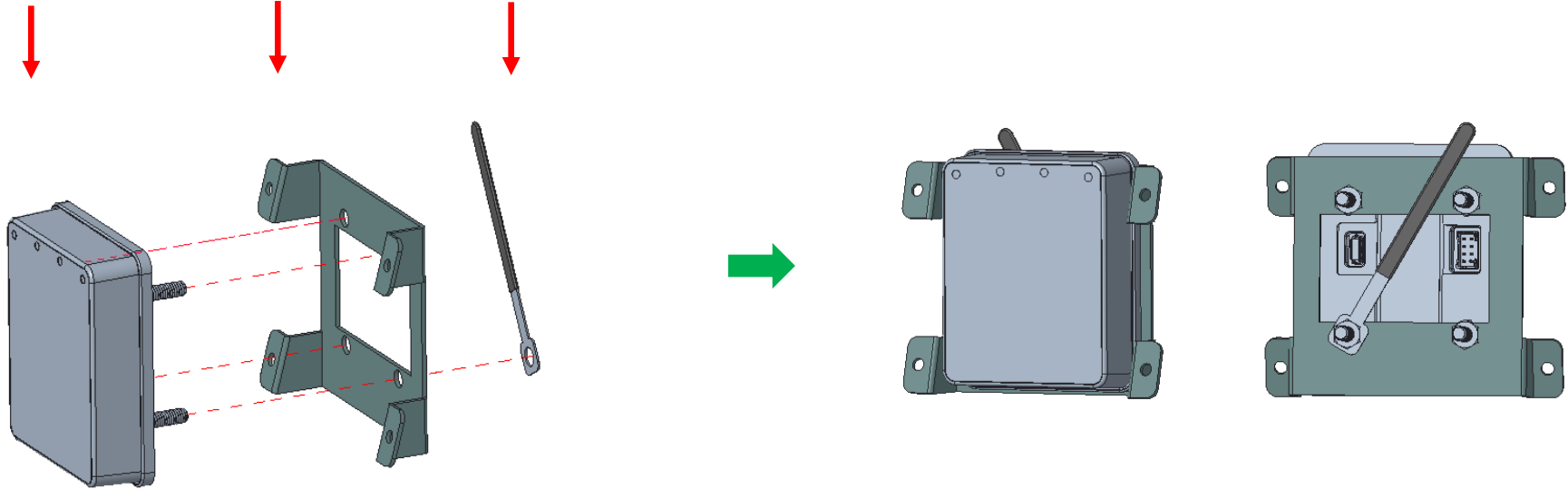

- Subassembly NFC and cover sheet metal.

[Step 2-3] Assembly NFC Module

No.	Part No.	Qty	Item
4	44651302	1	SCREW:PH:M3X6:S/W:F/W(L):W/ZN
5	340000084	1	USB_CABLE:AM TO MICB:STR:2.5M (MX5300A/S)

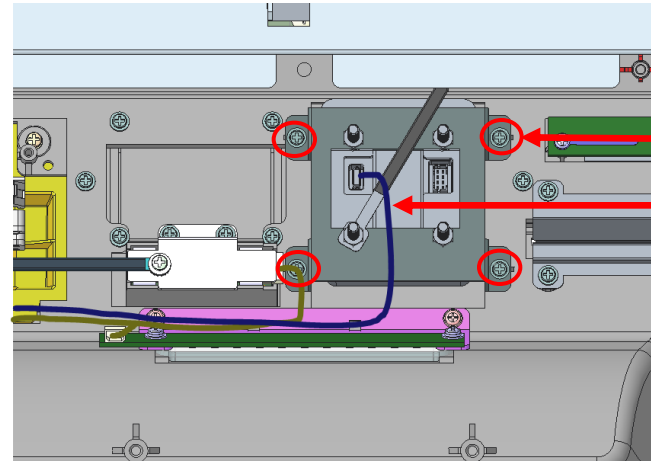
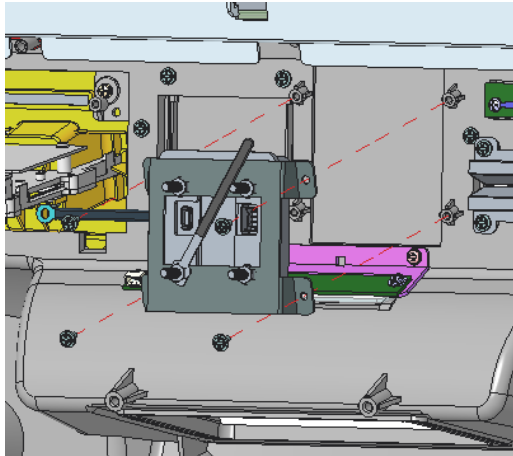

④ 44683701

⑤
340000084

- Assembly the subassembly.

[Step 2-4] Assembly NFC Module

No.	Part No.	Qty	Item
7	5721002549	1	LABEL:RF:MX5300A



- Assembly the label.